

THESE DRAWINGS ARE THE PROPERTY OF QUALTEK ELECTRONICS AND NOT TO BE REPRODUCED FOR OR COMMUNICATED TO A THIRD PARTY WITHOUT THE EXPRESS WRITTEN PERMISSION OF AN OFFICER OF QUALTEK ELECTRONICS.

REVISION			
REV.	DESCRIPTION	DATE	APPROVED
B	RoHS Compliancy	06-01-06	DP

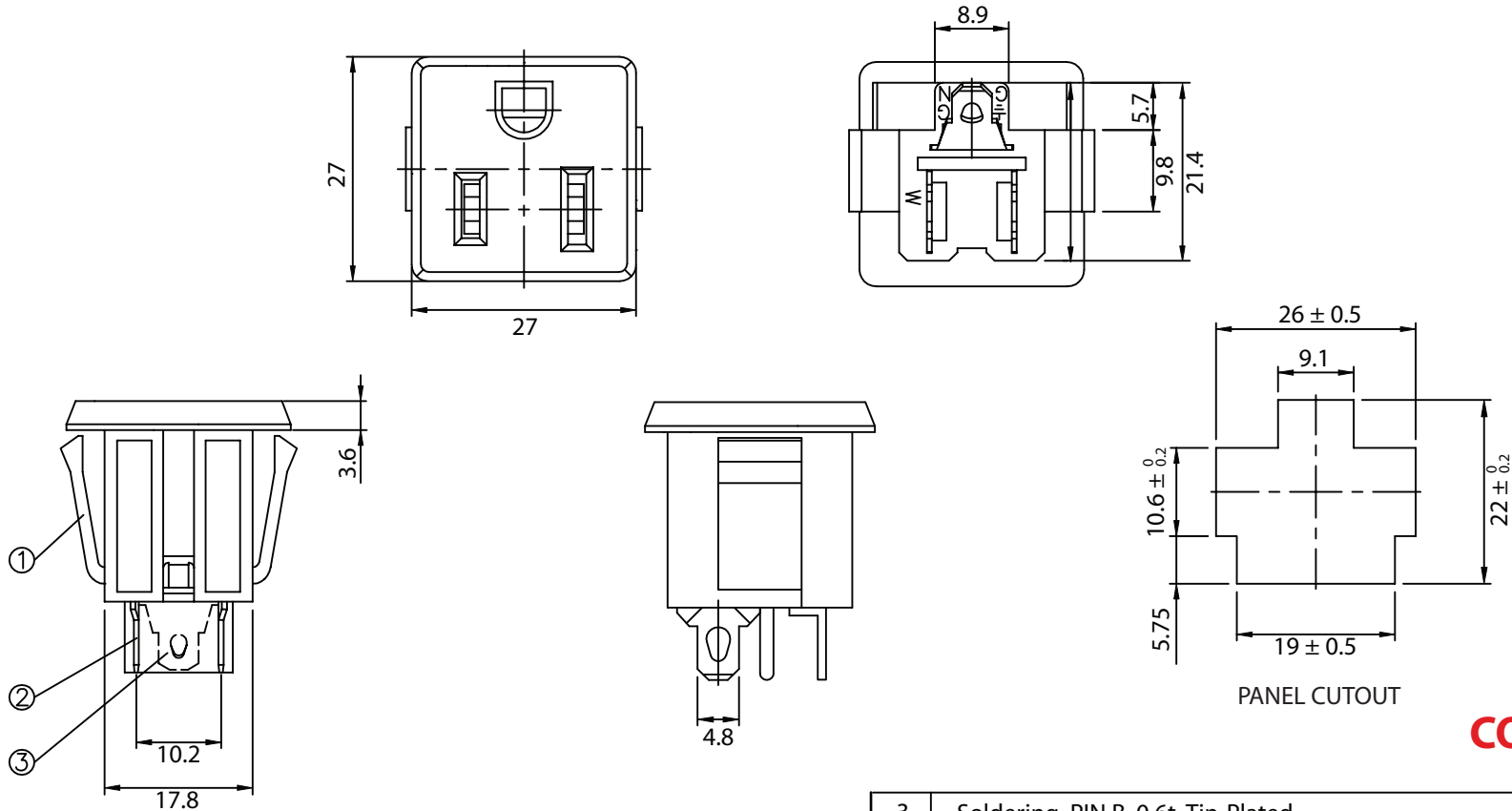

**CONTROLLED**

NOTES:

RATING: 15A 125V AC  
 APPROVALS: UL,CSA  
 PANEL THICKNESS: 0.8mm~2.0mm  
 RoHS COMPLIANT

3	Soldering PIN B 0.6t Tin-Plated	1
2	Soldering PIN A 0.6t Tin-Plated	2
1	Body Insulator NYLON 21SP Black Color	1

Dim range (mm)	Tolerance +/- (mm)	Qualtek Electronics Corp. PPC DIVISION		
		Part Number:	738W-X2/04	
0-1	0.15	Description: AC RECEPTACLE		
1-6	0.20		UNIT: mm	REV. B
6-18	0.30			
18-50	0.50			
50-120	0.70	Drawn / Date	Checked / Date	Approved / Date
120-250	0.90	B.ZHANG 10-22-01	10-22-01	JJH / 10-22-01
250-500	1.20			