

THESE DRAWINGS ARE THE PROPERTY OF QUALTEK ELECTRONICS AND NOT TO BE REPRODUCED FOR OR COMMUNICATED TO A THIRD PARTY WITHOUT THE EXPRESS WRITTEN PERMISSION OF AN OFFICER OF QUALTEK ELECTRONICS.

REVISION			
REV.	DESCRIPTION	DATE	APPROVED

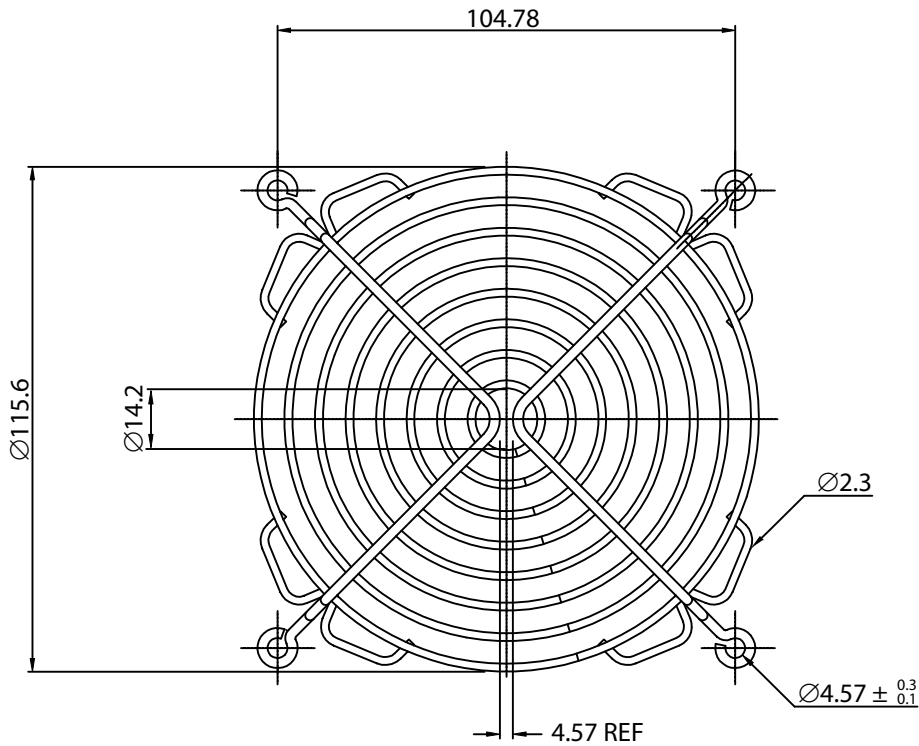

NOTES:

1. MATERIAL: STAINLESS STEEL WIRE
2. FINISH: ELECTROLYZE
3. 0.35 ± 0.05 DEPTH OF SERRATIONS ON WIRE
4. RING: Ø1.8 ± 0.1mm  
RIB: Ø1.8mm±0.1mm & Ø2.3 ± 0.1mm
5. GENERAL TOLERANCE UNLESS NOTED IS ± 0.5mm
6. RoHS COMPLIANT

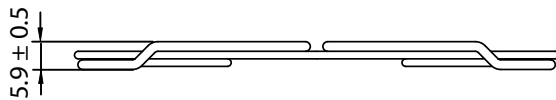

**CONTROLLED**

Dim range (mm)	Tolerance +/- (mm)	Qualtek Electronics Corp. FAN-S DIVISION		
		Part Number:	80128-SS	RoHS Compliant
0-5	0.1	Description: WIRE FORM FAN GUARD (120mm)		
5-16	0.15		UNIT: mm	
16-64	0.2			
64-250	0.4	Drawn / Date	Checked / Date	Approved / Date
250-1000	0.5	R.Nuti 10-21-08	10-21-08	LY / 10-21-08
1000-1500	1.0			