

THESE DRAWINGS ARE THE PROPERTY OF QUALTEK ELECTRONICS AND NOT TO BE REPRODUCED FOR OR COMMUNICATED TO A THIRD PARTY WITHOUT THE EXPRESS WRITTEN PERMISSION OF AN OFFICER OF QUALTEK ELECTRONICS.

REVISION			
REV.	DESCRIPTION	DATE	APPROVED
A	RoHS Compliancy	06-01-06	DP

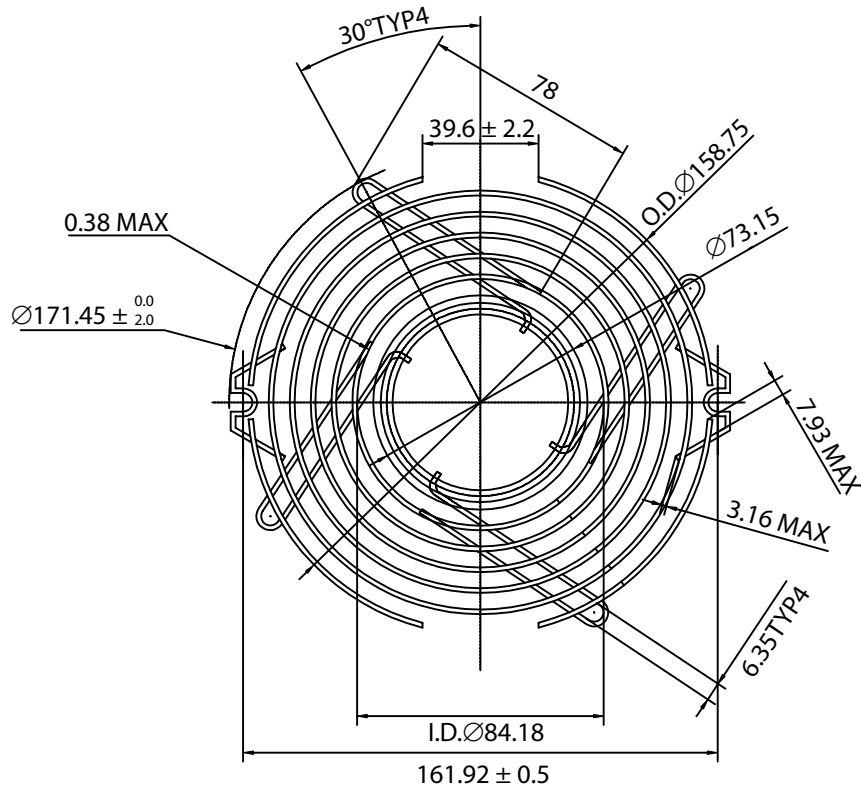

NOTES:

1. MATERIAL: SUS304
2. FINISH: ELECTROLYSIS ALL WIRE
3. 0.30 ± 0.05 DEPTH OF SERRATIONS ON WIRE
4. RING: $\varnothing 1.6 \pm 0.1\text{mm}$
RIB: $\varnothing 1.6 \pm 0.1\text{mm}$
WING: $\varnothing 1.8 \pm 0.1\text{mm}$
IRON PLATE: $t=0.8$
5. GENERAL TOLERANCE UNLESS NOTED IS $\pm 0.5\text{mm}$
6. RoHS COMPLIANT

CONTROLLED



Dim range (mm)		Tolerance +/- (mm)	Qualtek Electronics Corp. FAN-S DIVISION		
0-5	0.1	Part Number: 08151-SS RoHS Compliant	Description: WIRE FORM FAN GUARD (150mm)		
5-16	0.15				
16-64	0.2		UNIT: mm	REV: A	
64-250	0.4	Drawn / Date	Checked / Date	Approved / Date	
250-1000	0.5	B. ZHANG 11-17-03	11-17-03	JH / 11-17-03	
1000-1500	1.0				