

THESE DRAWINGS ARE THE PROPERTY OF QUALTEK ELECTRONICS AND NOT TO BE REPRODUCED FOR OR COMMUNICATED TO A THIRD PARTY WITHOUT THE EXPRESS WRITTEN PERMISSION OF AN OFFICER OF QUALTEK ELECTRONICS.

REVISION			
REV.	DESCRIPTION	DATE	APPROVED

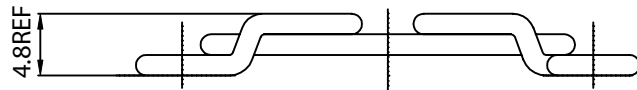
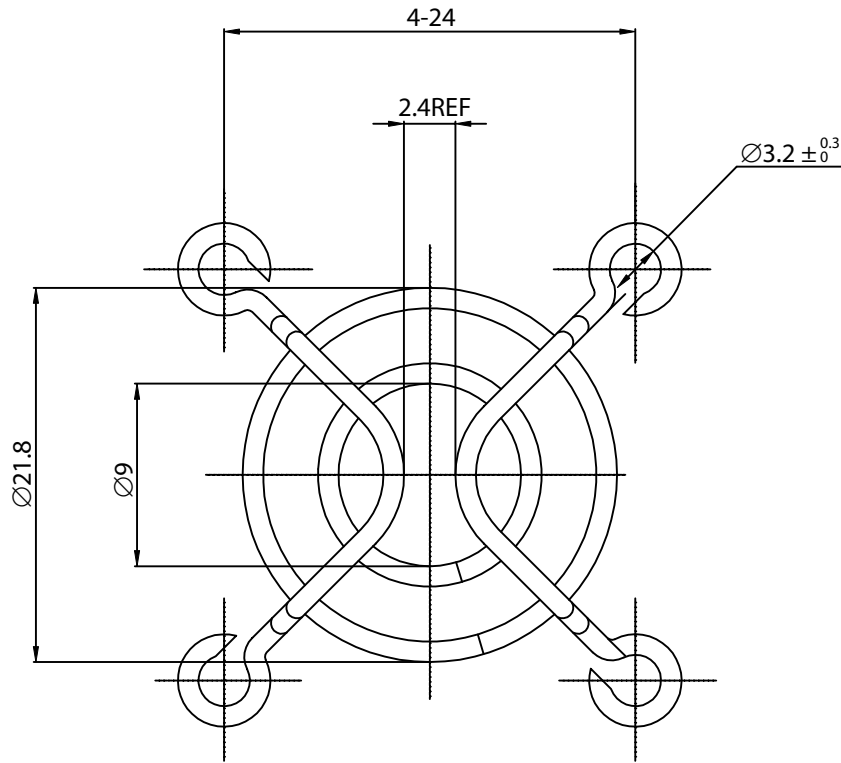

NOTES:

1. MATERIAL: 304 STAINLESS STEEL WIRE
2. FINISH: ELECTROLYSIS
3. 0.35 ± 0.05 DEPTH OF SERRATIONS ON WIRE
4. RING: Ø1.6 ± 0.1mm
RIB: Ø1.6 ± 0.1mm
5. GENERAL TOLERANCE UNLESS NOTED IS ± 0.5mm
6. RoHS COMPLIANT

CONTROLLED

Dim range (mm)	Tolerance +/- (mm)	Qualtek Electronics Corp. FAN-S DIVISION		
0-1	0.15	Part Number: 08346-SS		
1-6	0.20	Description: WIRE FORM FAN GUARD (30mm)		
6-18	0.30	UNIT: mm		
18-50	0.50	Drawn / Date	Checked / Date	Approved / Date
50-120	0.70	R. Nuti 02-23-16	02-23-16	LY / 02-23-16
120-250	0.90			
250-500	1.20			