

THESE DRAWINGS ARE THE PROPERTY OF QUALTEK ELECTRONICS AND NOT TO BE REPRODUCED FOR OR COMMUNICATED TO A THIRD PARTY WITHOUT THE EXPRESS WRITTEN PERMISSION OF AN OFFICER OF QUALTEK ELECTRONICS.

REVISION			
REV.	DESCRIPTION	DATE	APPROVED

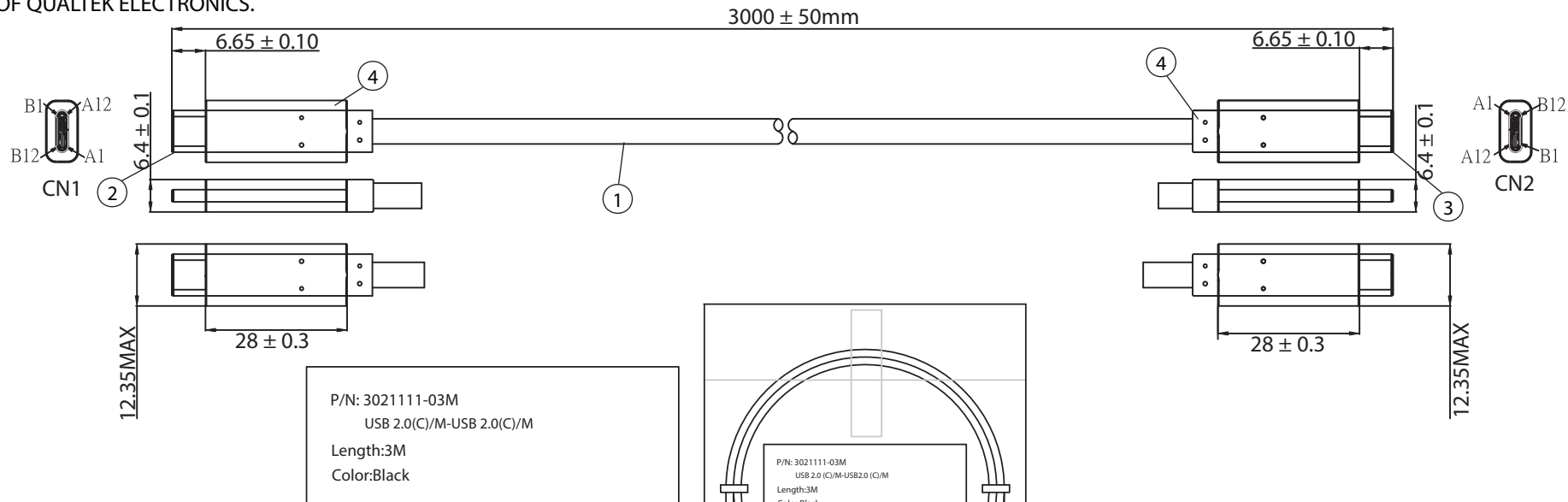

**NOTES:**

- CABLE:**  
26AWGx1PR+32AWGx2C+22AWGx2C+AEB 85%  
PVC OUTER JACKET: BLACK, OD: 4.6 ± 0.2mm
- CONNECTOR: USB 2.0 TYPE C MALE**  
INSULATOR: BLACK PBT  
PIN GOLD PLATED  
NICKEL PLATED SHELL
- CONNECTOR: USB 2.0 TYPE C MALE**  
INSULATOR: BLACK PBT  
PIN GOLD PLATED  
NICKEL PLATED SHELL  
PCB WITH E-MARK
- PVC MOLDED: COLOR BLACK**
- ELECTRICAL TEST:**  
<1>.100% OPEN SHORT & MISS WIRE TEST  
<2>. HI-POT: 50V AC/0.01 SEC 50V DC/0.01 SEC  
<3>. INSULATION RESISTANCE: 10M OHM (MIN)  
<4>. CONDUCTIVE RESISTANCE: 3 OHM (MAX)  
<5>. CAPACITANCE DETECTION: 20nF ± 20% BETWEEN A1 AND A4
- DATA TRANSFER RATE UP TO 480Mbps (NOMINAL)**
- CURRENT RATING UP TO 5A (NOMINAL)**
- VOLTAGE RATING UP TO 20V (NOMINAL)**
- PACKING: 1PC/POLYBAG W/ LABEL**

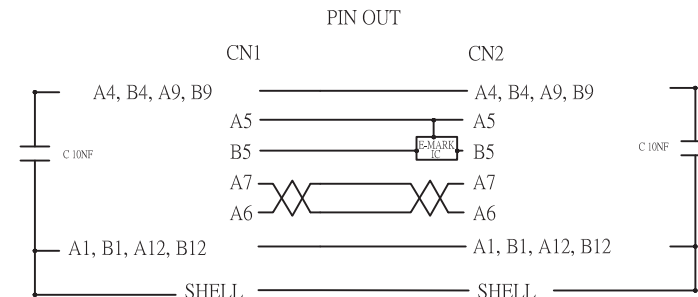

**CONTROLLED**

Dim range (mm)	Tolerance +/- (mm)	Qualtek Electronics Corp. WCI DIVISION		
		Part Number: 3021111-03M	RoHS Compliant	
0-1	0.15	Description: USB 2.0(C)/M - USB 2.0 (C)/M		
1-6	0.20	UNIT: mm		
6-18	0.30	UNIT: mm		
18-50	0.50	UNIT: mm		
50-120	0.70	Drawn / Date	Checked / Date	Approved / Date
120-250	0.90	R. Nuti 09-21-21	09-21-21	LY / 09-21-21
250-500	1.20			