

THESE DRAWINGS ARE THE PROPERTY OF QUALTEK ELECTRONICS AND NOT TO BE REPRODUCED FOR OR COMMUNICATED TO A THIRD PARTY WITHOUT THE EXPRESS WRITTEN PERMISSION OF AN OFFICER OF QUALTEK ELECTRONICS.

REVISION			
REV.	DESCRIPTION	DATE	APPROVED
B	Added Dimensions	03-03-11	LY

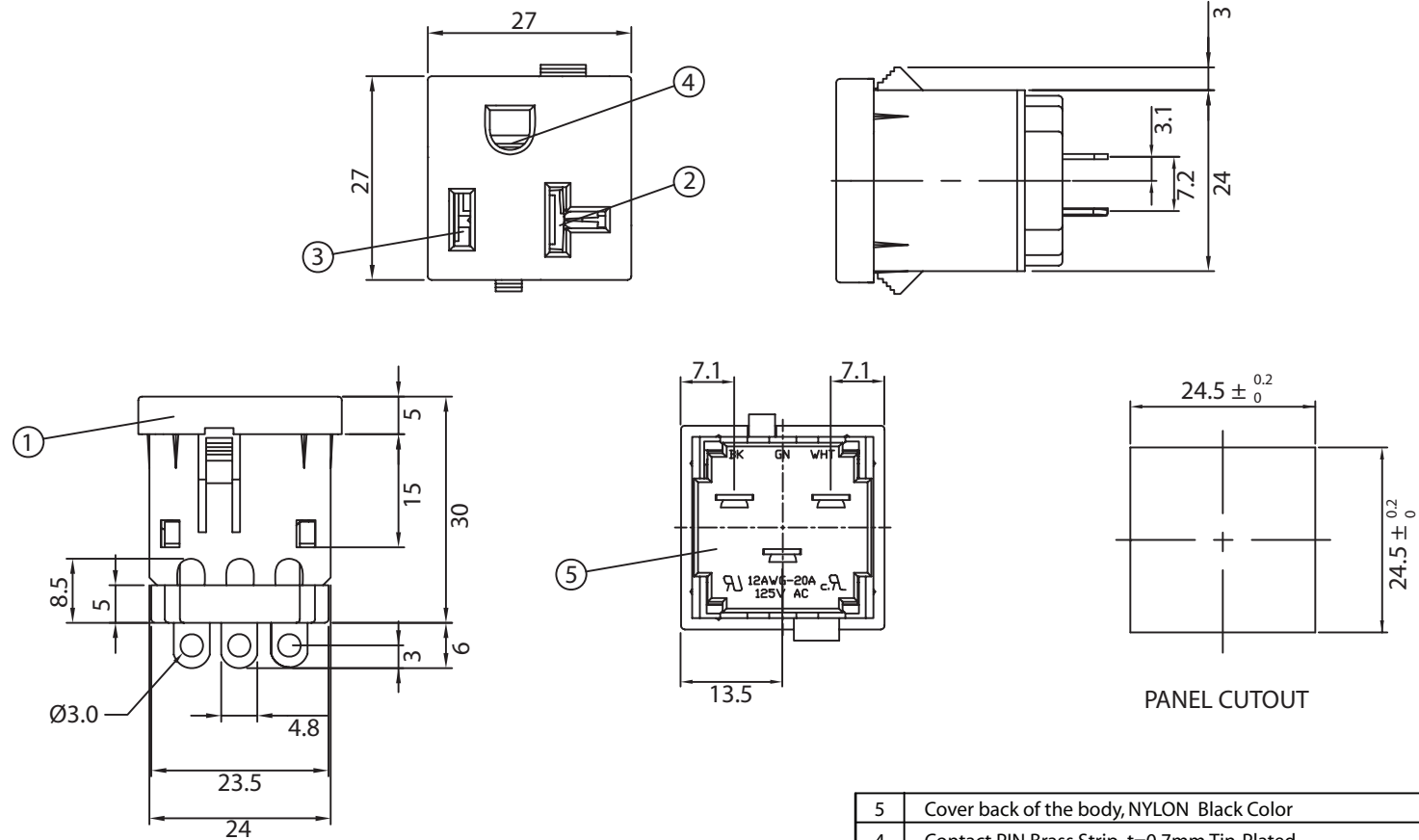

CONTROLLED

NOTES:

USE 12AWG SOLID WIRE ONLY
 RATING: 20A 125V
 APPROVALS: UL,cUL
 PANEL THICKNESS: 0.8~1.8mm
 RoHS COMPLIANT

5	Cover back of the body, NYLON Black Color	1
4	Contact PIN Brass Strip t=0.7mm Tin-Plated	1
3	Contact PIN Brass Strip t=0.7mm Tin-Plated	1
2	Contact PIN Brass Strip t=0.7mm Tin-Plated	1
1	Body Insulator NYLON	1

Dim range (mm)	Tolerance +/- (mm)	Qualtek Electronics Corp. PPC DIVISION		
		Part Number: 739W-X2/31	RoHS Compliant	
0-1	0.15	Description: AC RECEPTACLE		
1-6	0.20			
6-18	0.30			
18-50	0.50			
50-120	0.70	UNIT: mm	REV. B	
120-250	0.90	Drawn / Date	Checked / Date	Approved / Date
250-500	1.20	R.Nuti 05-27-07	05-27-07	JJH / 05-27-07